

Gutor PXC

75–100 kVA UPS with Transformer

Installation

GUPXC75GFI, GUPXC75GFDI, GUPXC75LFI, GUPXC75LFDI, GUPXC100GFI,
GUPXC100GFDI, GUPXC100LFI, GUPXC100LFDI,

11/2017



Legal Information

The Schneider Electric brand and any registered trademarks of Schneider Electric Industries SAS referred to in this guide are the sole property of Schneider Electric SA and its subsidiaries. They may not be used for any purpose without the owner's permission, given in writing. This guide and its content are protected, within the meaning of the French intellectual property code (Code de la propriété intellectuelle français, referred to hereafter as "the Code"), under the laws of copyright covering texts, drawings and models, as well as by trademark law. You agree not to reproduce, other than for your own personal, noncommercial use as defined in the Code, all or part of this guide on any medium whatsoever without Schneider Electric's permission, given in writing. You also agree not to establish any hypertext links to this guide or its content. Schneider Electric does not grant any right or license for the personal and noncommercial use of the guide or its content, except for a non-exclusive license to consult it on an "as is" basis, at your own risk. All other rights are reserved.

Electrical equipment should be installed, operated, serviced, and maintained only by qualified personnel. No responsibility is assumed by Schneider Electric for any consequences arising out of the use of this material.

As standards, specifications, and designs change from time to time, please ask for confirmation of the information given in this publication.

Table of Contents

Important Safety Instructions — SAVE THESE	
INSTRUCTIONS	5
FCC Statement	6
Safety Precautions	6
Electrical Safety	8
Battery Safety	9
Specifications	10
Input Specifications	10
Bypass Specifications	10
Output Specifications	10
Battery Specifications	11
Torque Specifications	11
Recommended Upstream Protection	12
Recommended Cable Sizes	12
UPS Weights and Dimensions	13
Clearance	13
Environment	14
Heat Dissipation	14
Installation	15
Installation Procedure for 75–100 kVA UPS – Single Mains	15
Installation Procedure for 75–100 kVA UPS – Dual Mains	17
Remove the Kick Plates	19
Install the Seismic Anchoring (Option)	19
Prepare the UPS and Transformer Cabinets for Cables	20
Prepare the UPS Cabinet for Cables in Systems with Adjacent Battery Cabinet(s)	23
Connect the Power Cables for Single Mains	25
Connect the Power Cables for Dual Mains	28
Route the Signal Cables	32
Connect the Signal Cables	35
Connect the Battery Signal Cables	35
Connect the Remote Emergency Power Off (REPO)	38
Connect the Input Contacts and Output Relays (Option)	39
Final Installation Steps	40

Important Safety Instructions — SAVE THESE INSTRUCTIONS

Read these instructions carefully and look at the equipment to become familiar with it before trying to install, operate, service or maintain it. The following safety messages may appear throughout this manual or on the equipment to warn of potential hazards or to call attention to information that clarifies or simplifies a procedure.



The addition of this symbol to a “Danger” or “Warning” safety message indicates that an electrical hazard exists which will result in personal injury if the instructions are not followed.



This is the safety alert symbol. It is used to alert you to potential personal injury hazards. Obey all safety messages with this symbol to avoid possible injury or death.

DANGER

DANGER indicates a hazardous situation which, if not avoided, **will result in death or serious injury**.

Failure to follow these instructions will result in death or serious injury.

WARNING

WARNING indicates a hazardous situation which, if not avoided, **could result in death or serious injury**.

Failure to follow these instructions can result in death, serious injury, or equipment damage.

CAUTION

CAUTION indicates a hazardous situation which, if not avoided, **could result in minor or moderate injury**.

Failure to follow these instructions can result in injury or equipment damage.

NOTICE

NOTICE is used to address practices not related to physical injury. The safety alert symbol shall not be used with this type of safety message.

Failure to follow these instructions can result in equipment damage.

Please Note

Electrical equipment should only be installed, operated, serviced, and maintained by qualified personnel. No responsibility is assumed by Schneider Electric for any consequences arising out of the use of this material.

A qualified person is one who has skills and knowledge related to the construction, installation, and operation of electrical equipment and has received safety training to recognize and avoid the hazards involved.

FCC Statement

NOTE: This equipment has been tested and found to comply with the limits for a Class A digital device, pursuant to Part 15 of the FCC Rules. These limits are designed to provide reasonable protection against harmful interference when the equipment is operated in a commercial environment. This equipment generates, uses, and can radiate radio frequency energy and, if not installed and used in accordance with the instruction manual, may cause harmful interference to radio communications. Operation of this equipment in a residential area is likely to cause harmful interference in which case the user will be required to correct the interference at his own expense.

Any changes or modifications not expressly approved by the party responsible for compliance could void the user’s authority to operate the equipment.

Safety Precautions

⚠ DANGER

HAZARD OF ELECTRIC SHOCK, EXPLOSION, OR ARC FLASH

All safety instructions in this document must be read, understood and followed.

Failure to follow these instructions will result in death or serious injury.

⚠ DANGER

HAZARD OF ELECTRIC SHOCK, EXPLOSION, OR ARC FLASH

Read all instructions in the Installation Manual before installing or working on this UPS system.

Failure to follow these instructions will result in death or serious injury.

⚠ DANGER

HAZARD OF ELECTRIC SHOCK, EXPLOSION, OR ARC FLASH

Do not install the UPS system until all construction work has been completed and the installation room has been cleaned.

Failure to follow these instructions will result in death or serious injury.

⚠ DANGER

HAZARD OF ELECTRIC SHOCK, EXPLOSION, OR ARC FLASH

- The product must be installed according to the specifications and requirements as defined by Schneider Electric. It concerns in particular the external and internal protections (upstream breakers, battery breakers, cabling, etc.) and environmental requirements. No responsibility is assumed by Schneider Electric if these requirements are not respected.
- After the UPS system has been electrically wired, do not start up the system. Start-up must only be performed by Schneider Electric.

Failure to follow these instructions will result in death or serious injury.

⚠ DANGER

HAZARD OF ELECTRIC SHOCK, EXPLOSION, OR ARC FLASH

The UPS system must be installed according to local and national regulations. Install the UPS according to:

- IEC 60364 (including 60364–4–41- protection against electric shock, 60364–4–42 - protection against thermal effect, and 60364–4–43 - protection against overcurrent), **or**
- NEC NFPA 70, **or**
- Canadian Electrical Code (C22.1, Part 1)

depending on which one of the standards apply in your local area.

Failure to follow these instructions will result in death or serious injury.

⚠ DANGER

HAZARD OF ELECTRIC SHOCK, EXPLOSION, OR ARC FLASH

- Install the UPS system in a temperature controlled indoor environment free of conductive contaminants and humidity.
- Install the UPS system on a non-flammable, level and solid surface (e.g. concrete) that can support the weight of the system.

Failure to follow these instructions will result in death or serious injury.

⚠ DANGER

HAZARD OF ELECTRIC SHOCK, EXPLOSION, OR ARC FLASH

The UPS is not designed for and must therefore not be installed in the following unusual operating environments:

- Damaging fumes
- Explosive mixtures of dust or gases, corrosive gases, or conductive or radiant heat from other sources
- Moisture, abrasive dust, steam or in an excessively damp environment
- Fungus, insects, vermin
- Salt-laden air or contaminated cooling refrigerant
- Pollution degree higher than 2 according to IEC 60664-1
- Exposure to abnormal vibrations, shocks, and tilting
- Exposure to direct sunlight, heat sources, or strong electromagnetic fields

Failure to follow these instructions will result in death or serious injury.

⚠ DANGER

HAZARD OF ELECTRIC SHOCK, EXPLOSION, OR ARC FLASH

Do not drill or cut holes for cables or conduits with the gland plates installed and do not drill or cut holes in close proximity to the UPS.

Failure to follow these instructions will result in death or serious injury.

⚠ WARNING

HAZARD OF ARC FLASH

Do not make mechanical changes to the product (including removal of cabinet parts or drilling/cutting of holes) that are not described in the Installation Manual.

Failure to follow these instructions can result in death, serious injury, or equipment damage.

NOTICE**RISK OF OVERHEATING**

Respect the space requirements around the UPS system and do not cover the product's ventilation openings when the UPS system is in operation.

Failure to follow these instructions can result in equipment damage.

NOTICE**RISK OF EQUIPMENT DAMAGE**

Do not connect the UPS output to regenerative load systems including photovoltaic systems and speed drives.

Failure to follow these instructions can result in equipment damage.

Electrical Safety

This manual contains important safety instructions that should be followed during the installation and maintenance of the UPS system.

⚠ DANGER**HAZARD OF ELECTRIC SHOCK, EXPLOSION, OR ARC FLASH**

- Electrical equipment must be installed, operated, serviced, and maintained only by qualified personnel.
- Apply appropriate personal protective equipment (PPE) and follow safe electrical work practices.
- Disconnection devices for AC and DC must be provided by others, be readily accessible, and the function of the disconnect device marked for its function.
- Turn off all power supplying the UPS system before working on or inside the equipment.
- Before working on the UPS system, check for hazardous voltage between all terminals including the protective earth.
- The UPS contains an internal energy source. Hazardous voltage can be present even when disconnected from the mains supply. Before installing or servicing the UPS system, ensure that the units are OFF and that mains and batteries are disconnected. Wait five minutes before opening the UPS to allow the capacitors to discharge.
- The UPS must be properly earthed/grounded and due to a high leakage current, the earthing/grounding conductor must be connected first.

Failure to follow these instructions will result in death or serious injury.

When the UPS input is connected through external isolators that, when opened, isolate the neutral or when the automatic backfeed isolation is provided external to the equipment or is connected to an IT power distribution system, a label must be fitted at the UPS input terminals, and on all primary power isolators installed remotely from the UPS area and on external access points between such isolators and the UPS, by the user, displaying the following text (or equivalent in a language which is acceptable in the country in which the UPS system is installed):

⚠ DANGER**HAZARD OF ELECTRIC SHOCK, EXPLOSION, OR ARC FLASH**

Risk of voltage backfeed. Before working on this circuit: Isolate the UPS and check for hazardous voltage between all terminals including the protective earth.

Failure to follow these instructions will result in death or serious injury.

Battery Safety

⚠ DANGER

HAZARD OF ELECTRIC SHOCK, EXPLOSION, OR ARC FLASH

- Battery circuit breakers must be installed according to the specifications and requirements as defined by Schneider Electric.
- Servicing of batteries must only be performed or supervised by qualified personnel knowledgeable of batteries and the required precautions. Keep unqualified personnel away from batteries.
- Disconnect charging source prior to connecting or disconnecting battery terminals.
- Do not dispose of batteries in a fire as they can explode.
- Do not open, alter, or mutilate batteries. Released electrolyte is harmful to the skin and eyes. It may be toxic.

Failure to follow these instructions will result in death or serious injury.

⚠ DANGER

HAZARD OF ELECTRIC SHOCK, EXPLOSION, OR ARC FLASH

Batteries can present a risk of electric shock and high short-circuit current. The following precautions must be observed when working on batteries

- Remove watches, rings, or other metal objects.
- Use tools with insulated handles.
- Wear protective glasses, gloves and boots.
- Do not lay tools or metal parts on top of batteries.
- Disconnect the charging source prior to connecting or disconnecting battery terminals.
- Determine if the battery is inadvertently grounded. If inadvertently grounded, remove source from ground. Contact with any part of a grounded battery can result in electric shock. The likelihood of such shock can be reduced if such grounds are removed during installation and maintenance (applicable to equipment and remote battery supplies not having a grounded supply circuit).

Failure to follow these instructions will result in death or serious injury.

⚠ DANGER

HAZARD OF ELECTRIC SHOCK, EXPLOSION, OR ARC FLASH

When replacing batteries, always replace with the same type and number of batteries or battery packs.

Failure to follow these instructions will result in death or serious injury.

NOTICE

RISK OF EQUIPMENT DAMAGE

- Wait until the system is ready to be powered up before installing batteries in the system. The time duration from battery installation until the UPS system is powered up must not exceed 72 hours or 3 days.
- Batteries must not be stored more than six months due to the requirement of recharging. If the UPS system remains de-energized for a long period, Schneider Electric recommends that you energize the UPS system for a period of 24 hours at least once every month. This charges the batteries, thus avoiding irreversible damage.

Failure to follow these instructions can result in equipment damage.

Specifications

Input Specifications

	75 kVA		100 kVA	
Input Voltage (V)	480	600	480	600
Connections	L1, L2, L3, N, G for single mains L1, L2, L3, G for dual mains, OR L1, L2, L3, N, G for dual mains			
Voltage range (V)	±10%			
Frequency (Hz)	60 ±8%			
Nominal input current ¹ (A)	100	80	133	106
Maximum input current ² (A)	125	100	167	134
Total harmonic distortion (THDI)	< 5% at 100% load			
Maximum input short-circuit rating	65 kA at 480 V 50 kA at 600 V			
Inrush current	11 x nominal input current			
Protection	Upstream protection according to source, preferable current limiting			
Ramp-in	10% nominal power/sec			

Bypass Specifications

	75 kVA		100 kVA	
Voltage (V)	480	600	480	600
Connections	L1, L2, L3, N, G			
Voltage range (V)	±10%			
Frequency (Hz)	60 ±8%			
Nominal bypass current (A)	90	72	120	96
Inrush current	11 x nominal input current			
Protection	Upstream protection according to source, preferable current limiting			

Output Specifications

	75 kVA	100 kVA
Voltage (V)	208	208
Connections	L1, L2, L3, N, G	
Overload capacity	150% for 1 minute 125% for 10 minutes 230% for 60 ms 1000% for 100 ms (bypass operation)	
Voltage range (V)	±1%	
Power factor	1	
Nominal output current (A)	208	278

1. Nominal input current based on nominal mains voltage and batteries fully charged at rated load.
2. Maximum input current based on nominal mains voltage and battery charging at rated load.

	75 kVA	100 kVA
Voltage (V)	208	208
Total harmonic distortion (THDU)	< 2% at 100% linear load < 5% at 100% non-linear load	
Frequency (Hz)	60 Hz (sync to bypass) 60 Hz \pm 0.1% (free-running)	
Slew rate (Hz/sec)	Programmable: 0.25, 0.5, 1, 2, or 4	
Load crest factor	3:1	
Load power factor	0.5 leading to 0.5 lagging without derating	

Battery Specifications

	75 kVA	100 kVA
Charging power in % of output power	20%	
Nominal battery voltage (VDC)	384	
Nominal float voltage (VDC)	436	
Boost charge voltage (VDC)	441	
End of discharge voltage (full load) (VDC)	321	
Battery current at full load and nominal battery voltage (A)	207	276
Battery current at full load and minimum battery voltage (A)	248	331
Restored energy time to 90% charge	Up to 8 hours	
Temperature compensation	Adjustable	
Ripple current	< 1%	
Battery test	Manual or automatic (selectable)	
Deep discharge protection	Yes	
Recharge according to battery temperature	Yes	
Cold start	Yes	

Torque Specifications

Bolt size	Torque
M3	0.63 (0.46 lb-ft)
M4	1.7 Nm (1.25 lb-ft)
M6	5 Nm (3.69 lb-ft)
M8	17.5 Nm (12.91 lb-ft)
M10	30 Nm (22 lb-ft)
M12	50 Nm (36.87 lb-ft)

Recommended Upstream Protection

⚠ DANGER

HAZARD OF ELECTRIC SHOCK, EXPLOSION, OR ARC FLASH

A suitable surge protective device rated not greater than 2500 V must be installed on the input source.

Failure to follow these instructions will result in death or serious injury.

80% rated circuit breaker	75 kVA		100 kVA	
	480	600	480	600
Input (A)	175	150	225	175
Bypass (A)	175	150	225	175

Recommended Cable Sizes

⚠ DANGER

HAZARD OF ELECTRIC SHOCK, EXPLOSION, OR ARC FLASH

All wiring must comply with all applicable national and/or electrical codes (National Electrical Code, ANSI/NFPA 70). The maximum allowable conductor size is 500 kcmil.

Failure to follow these instructions will result in death or serious injury.

Cable sizes in this manual are based on Table 310.15 of the National Electrical Code 2014 (NEC) with the following assertions:

- 90 °C conductors (THHN) for 75 °C termination
- Not more than one current carrying conductor per phase for 25-50 kVA UPS
- Not more than two current carrying conductor per phase for 75-100 kVA UPS
- Use of copper conductors only – do not use aluminum conductors.
- An ambient temperature of 30 °C

If the ambient temperature is greater than 30 °C, larger conductors are to be selected with the correction factors of the NEC. Equipment grounding conductors (EGC) are sized in accordance with NEC Article 250.122 and Table 250.122.

	75 kVA	100 kVA
Input	2/0 AWG	4/0 AWG
Bypass	2/0 AWG	4/0 AWG
Output	350 kcmil or 2 x 1/0 AWG	500 kcmil or 2 x 2/0 AWG
Battery	350 kcmil or 2 x 1/0 AWG	2 x 4/0 AWG

UPS Weights and Dimensions

	Weight kg (lbs)	Height mm (in)	Width mm (in)	Depth mm (in)
75 kVA with T001 input transformer	1329 (2950)	2100 (82.7)	1800 (70.9)	800 (31.5)
75 kVA with T001 input and T003 bypass transformer	1757 (3900)	2100 (82.7)	1800 (70.9)	800 (31.5)
100 kVA with T001 input transformer	1532 (3400)	2100 (82.7)	1800 (70.9)	800 (31.5)
100 kVA with T001 input and T003 bypass transformer	2095 (4650)	2100 (82.7)	1800 (70.9)	800 (31.5)

Clearance

75–100 kVA UPS

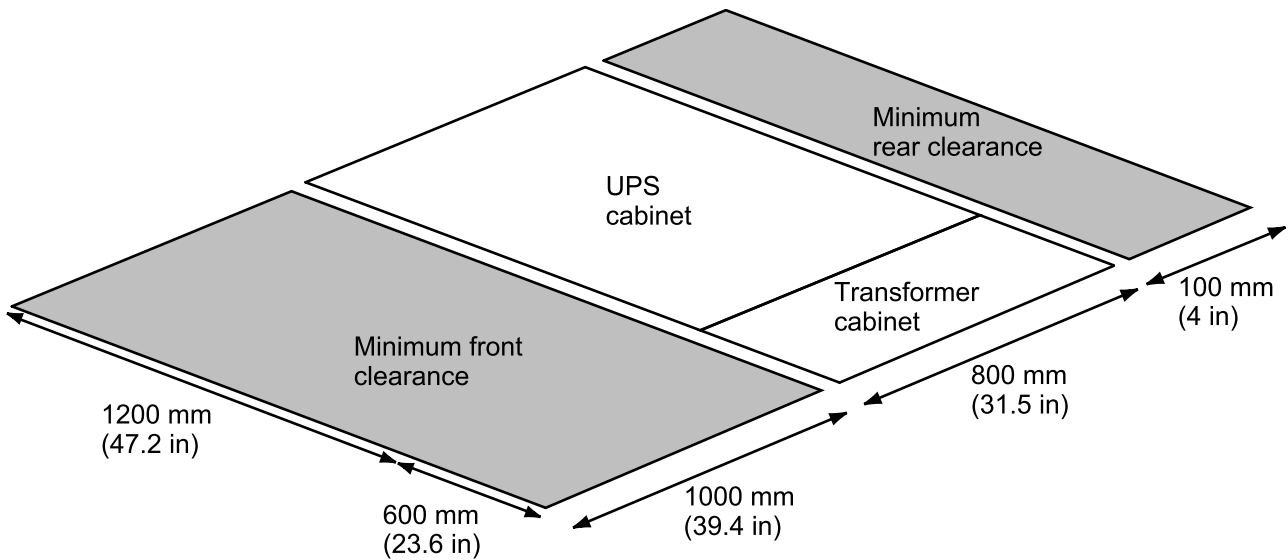

The UPS system requires a minimum rear clearance of 100 mm (4 in). There is no side clearance required for installation.

NOTE: If the optional filters are installed in the rear of the cabinets to obtain NEMA12 (IP54) rating, a rear clearance of 914 mm (36 in) is needed for replacement of the filters.

NOTE: Clearance dimensions are published for airflow only. Consult with the local safety codes and standards for additional requirements in your local area.

Environment

	Operating	Storage
Temperature	0 °C to 40 °C (32 °F to 104 °F) 0 °C to 25 °C (32 °F to 77 °F) for batteries	-30 °C to 80 °C (-22 °F to 176 °F) -15 °C to 40 °C (5 °F to 104 °F) for batteries
Relative humidity	0-95% non-condensing	0-95% non-condensing
Elevation according to IEC 62040-3	1000 m (3280 ft): 1.000 1500 m (4921 ft): 0.975 2000 m (6561 ft): 0.950 2500 m (8202 ft): 0.925 3000 m (9842 ft): 0.900	≤ 5000 m (16404 ft) above sea-level (or in an environment with equivalent atmospheric pressure)
Audible noise (1 m (3 ft) from surface)	65 dBA at 100% load	
Protection class	UL type 1/NEMA1 (IP42)	
Color	Light gray RAL7035	

Heat Dissipation

480–208 V

	75 kVA	100 kVA
Heat dissipation at 100% load (BTU/hr)	27490	36235
Heat dissipation at 75% load (BTU/hr)	19914	25929
Heat dissipation at 50% load (BTU/hr)	13432	17079
Heat dissipation at 25% load (BTU/hr)	9056	10976

600–208 V

	75 kVA	100 kVA
Heat dissipation at 100% load (BTU/hr)	28119	42608
Heat dissipation at 75% load (BTU/hr)	20853	30000
Heat dissipation at 50% load (BTU/hr)	14534	20967
Heat dissipation at 25% load (BTU/hr)	10850	15203

Installation

Installation Procedure for 75–100 kVA UPS – Single Mains

NOTE: Top and bottom entry is available.

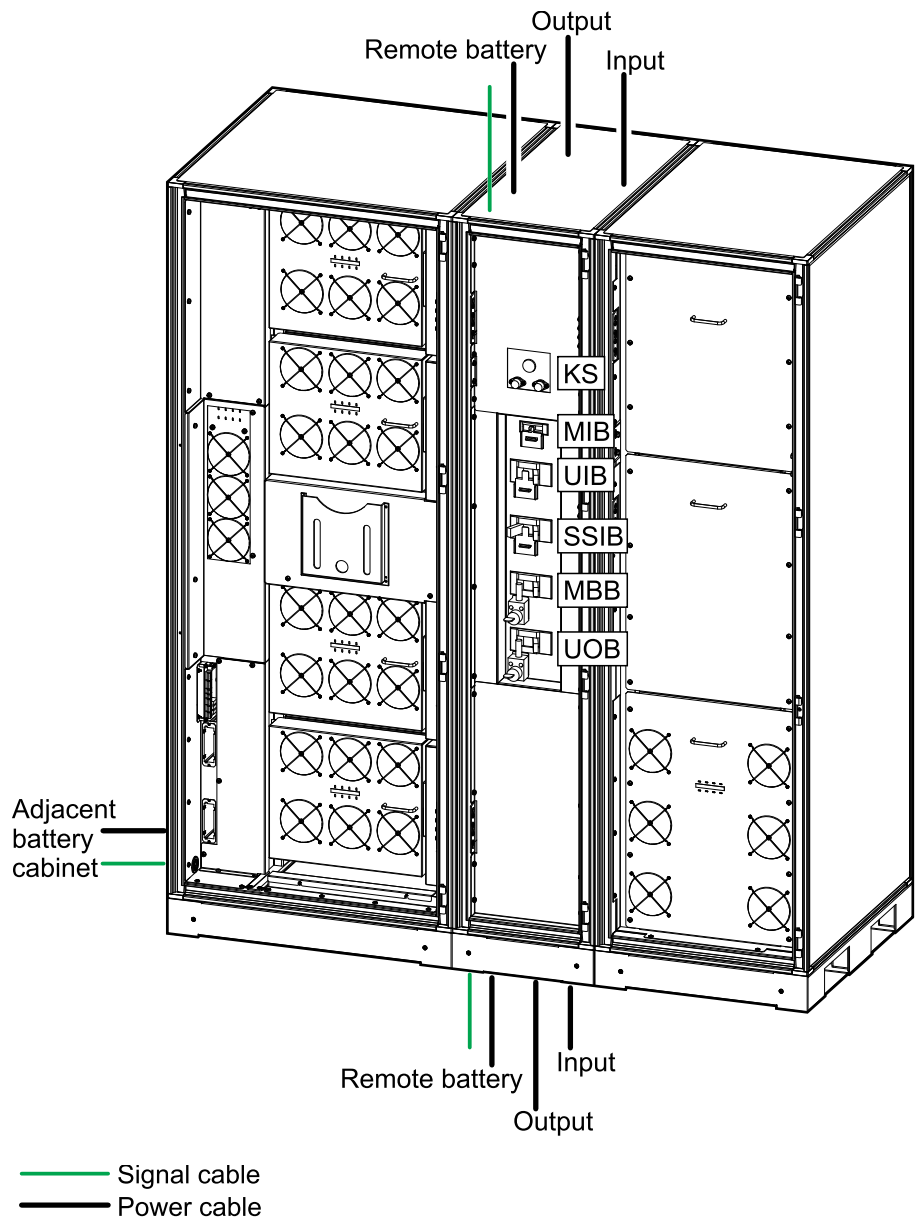

1. Move the cabinets to the final location with a forklift or a low profile 21 inch pallet jack by lifting from the sides.

▲ WARNING
TIPPING HAZARD
The cabinet is top-heavy. Move the cabinet carefully with a forklift or a low profile 21 inch pallet jack by lifting from the sides.
Failure to follow these instructions can result in death, serious injury, or equipment damage.

2. Remove the right side panel from the I/O section of the UPS cabinet and install the side panel on the right side of the transformer cabinet.
3. *Remove the Kick Plates, page 19.*

4. *Install the Seismic Anchoring (Option), page 19.*
5. *Prepare the UPS and Transformer Cabinets for Cables, page 20.*
6. *Only with adjacent battery cabinet(s): Prepare the UPS Cabinet for Cables in Systems with Adjacent Battery Cabinet(s), page 23.*
7. *Connect the Power Cables for Single Mains, page 25.*
8. *Route the Signal Cables, page 32.*
9. *Connect the Battery Signal Cables, page 35.*
10. *Connect the Remote Emergency Power Off (REPO), page 38.*
11. *Connect the Input Contacts and Output Relays (Option), page 39.*
12. *Final Installation Steps, page 40.*

Installation Procedure for 75–100 kVA UPS – Dual Mains

NOTE: Top and bottom entry is available.

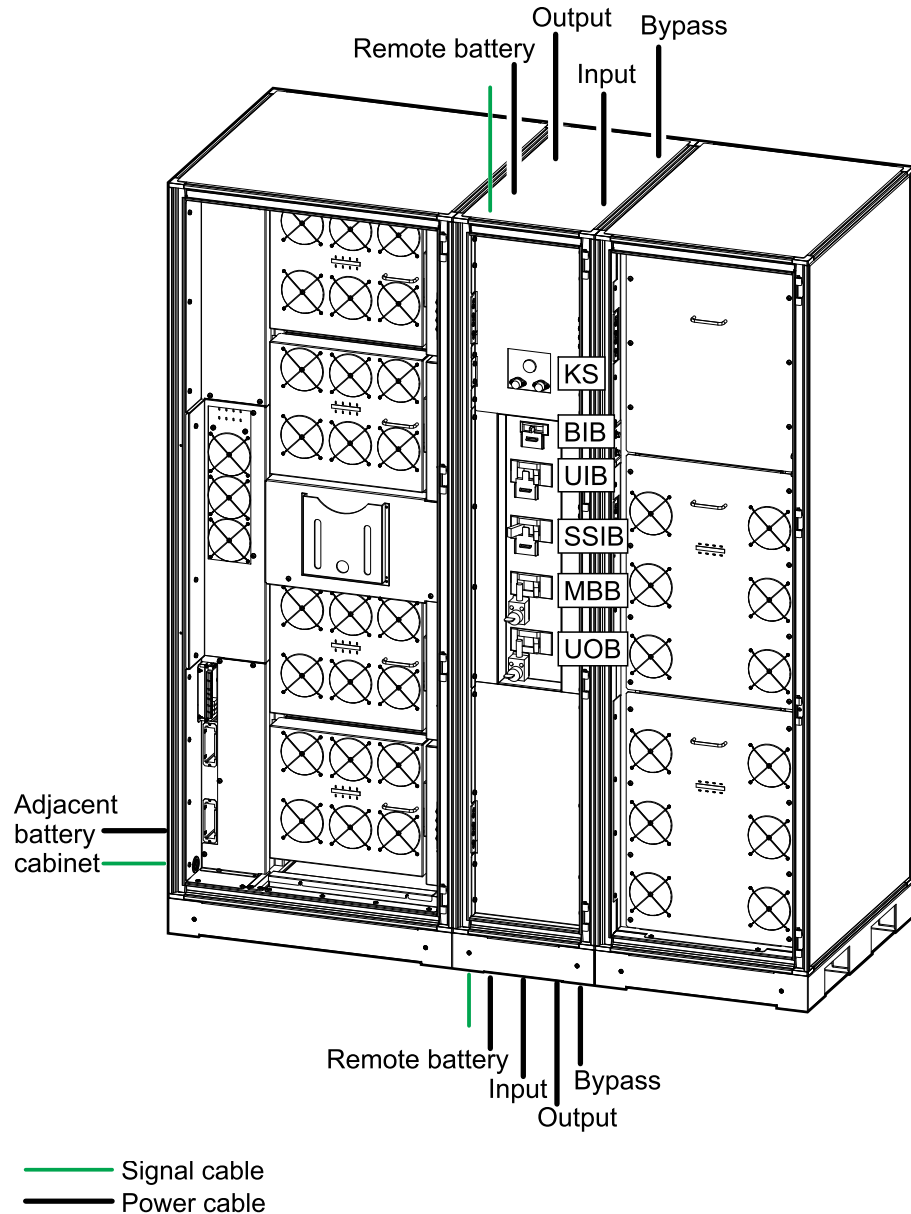

1. Move the cabinets to the final location with a forklift or a low profile 21 inch pallet jack by lifting from the sides.

⚠ WARNING

TIPPING HAZARD

The cabinet is top-heavy. Move the cabinet carefully with a forklift or a low profile 21 inch pallet jack by lifting from the sides.

Failure to follow these instructions can result in death, serious injury, or equipment damage.

2. Remove the right side panel from the I/O section of the UPS cabinet and install the side panel on the right side of the transformer cabinet.
3. *Remove the Kick Plates, page 19.*
4. *Install the Seismic Anchoring (Option), page 19.*
5. *Prepare the UPS and Transformer Cabinets for Cables, page 20.*

6. Only with adjacent battery cabinet(s): *Prepare the UPS Cabinet for Cables in Systems with Adjacent Battery Cabinet(s), page 23.*
7. *Connect the Power Cables for Dual Mains, page 28.*
8. *Route the Signal Cables, page 32.*
9. *Connect the Battery Signal Cables, page 35.*
10. *Connect the Remote Emergency Power Off (REPO), page 38.*
11. *Connect the Input Contacts and Output Relays (Option), page 39.*
12. *Final Installation Steps, page 40.*

Remove the Kick Plates

NOTE: Front and rear kick plates are removed in the same way on all the cabinets. Remove the kick plates as needed for cabling access and save for final installation steps.

1. Remove the M5 screws.
2. Remove the kick plate from the spring clips.

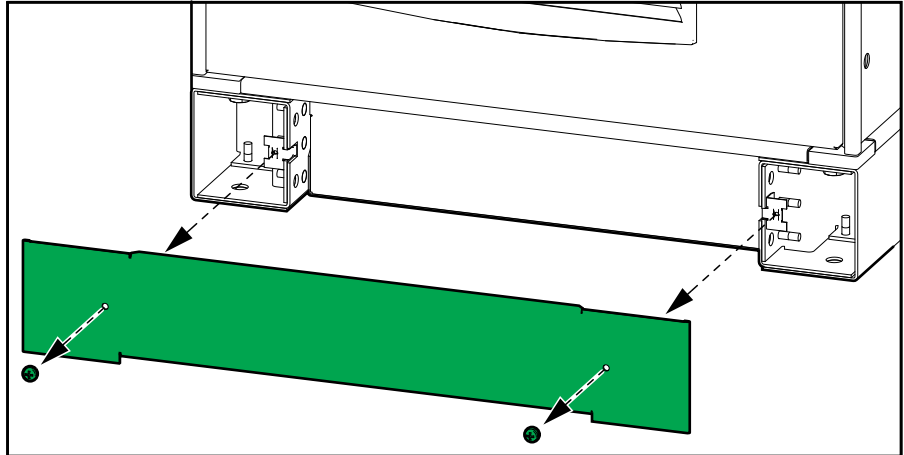

Install the Seismic Anchoring (Option)

NOTE: Anchoring bolts are not supplied. Use appropriate hardware for the floor type.

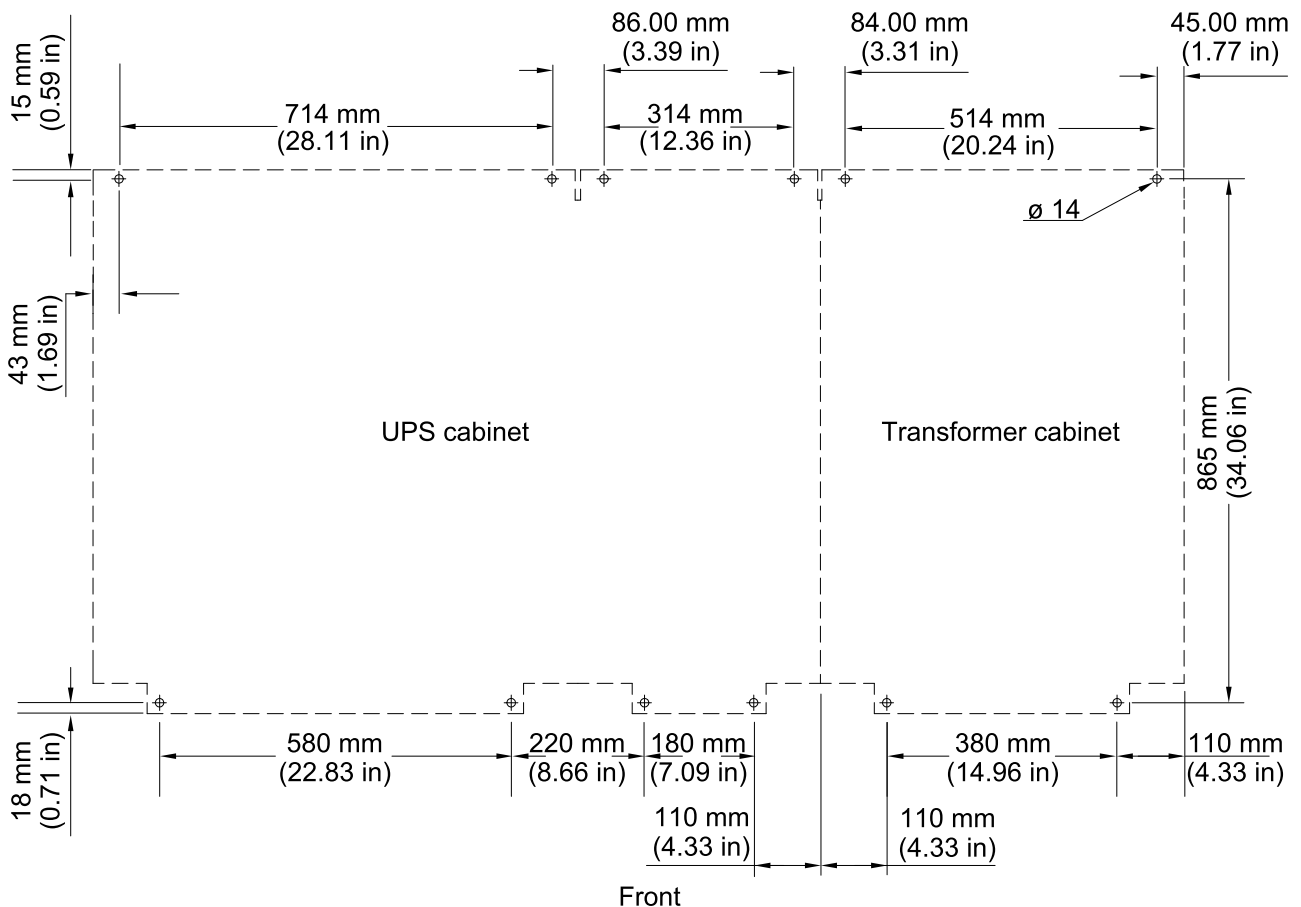

1. Make anchoring holes in the floor.

2. Install the rear seismic anchoring bracket(s) on the floor.

Front View

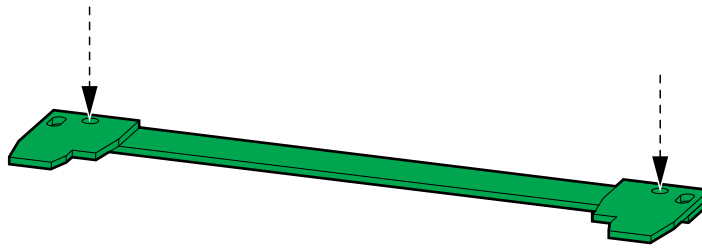

3. Push the cabinet(s) into position against the rear seismic anchoring brackets.

Rear View

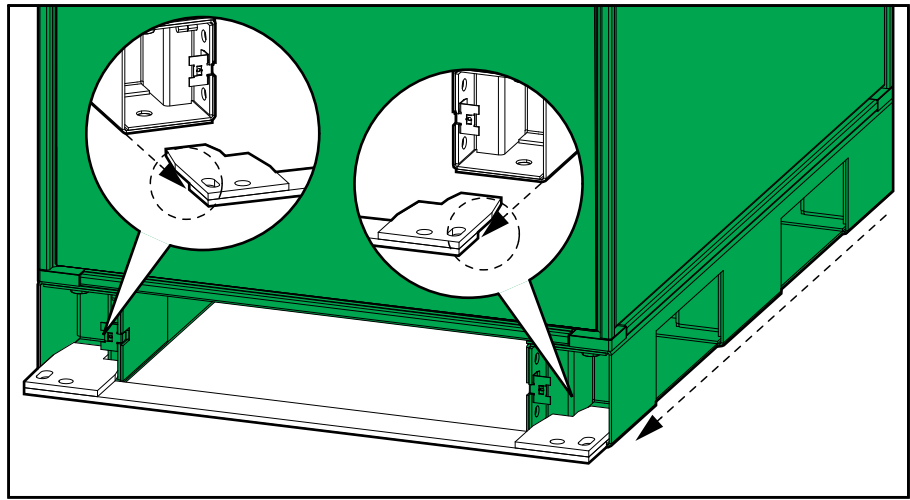

4. Save the front seismic anchoring brackets – they will be installed in *Final Installation Steps, page 40*.

Prepare the UPS and Transformer Cabinets for Cables

1. Remove the rear panel from the I/O section of the UPS cabinet and the transformer cabinet.
2. Remove the three plates from the transformer cabinet:
 - For fan plates: Remove the screws from the fan plate and tilt the fan plate out carefully. Disconnect the six pin molex that connects in the left side of the transformer cabinet. Remove the fan plate from the transformer cabinet.
 - For front plates: Remove the screws from the front plate and remove the front plate from the transformer cabinet.

3. Remove the bottom front plate in the I/O section of the UPS cabinet.

Front View of the UPS Cabinet and Transformer Cabinet (Dual Mains System Shown)

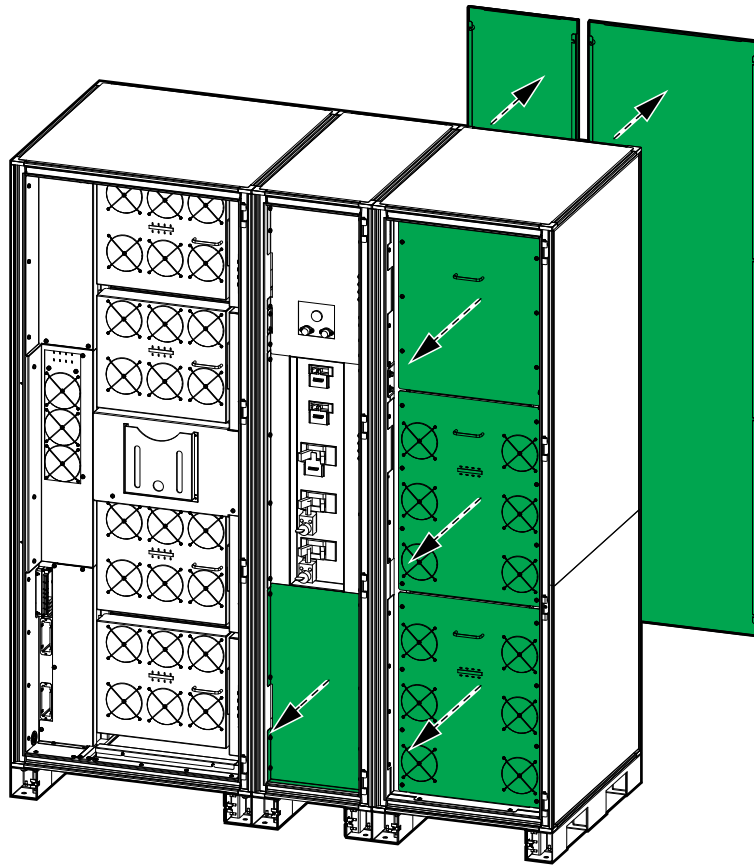

4. Install two interconnection brackets on the front of the cabinets and two interconnection brackets in the rear of the cabinets. Use C-clamps to hold the cabinets together to make the installation easier. Use four screws on each side of each interconnection bracket to fasten it to the cabinet frame.

Front View of I/O Section of the UPS Cabinet and Transformer Cabinet

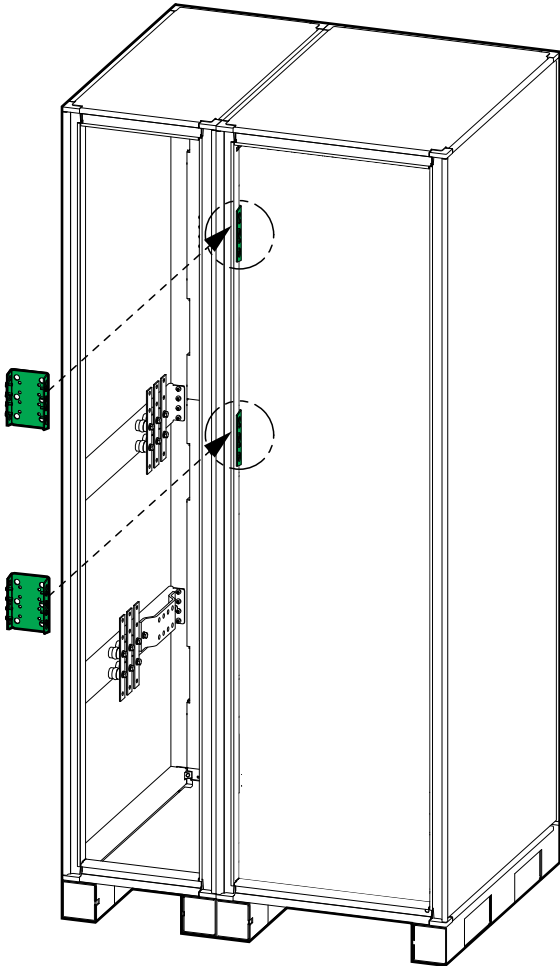

Rear View of Transformer Cabinet and I/O Section of the UPS Cabinet

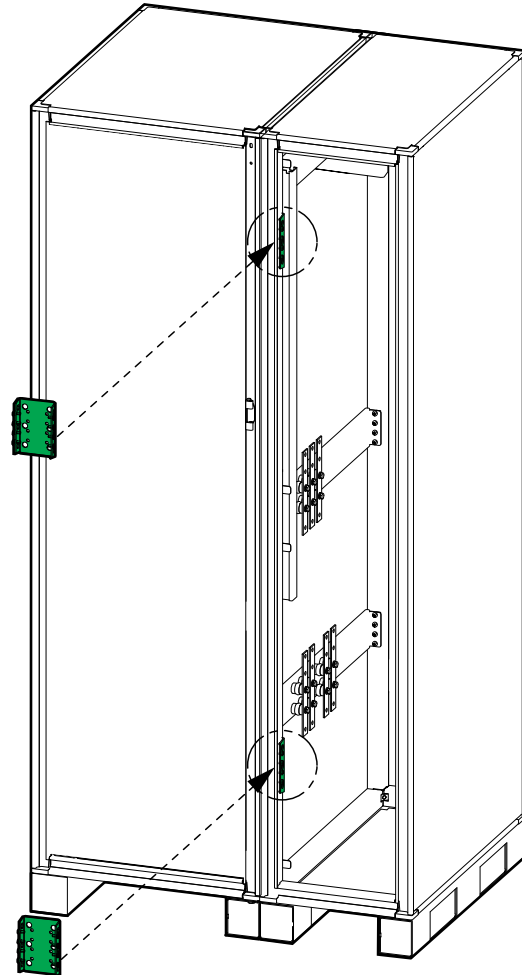

5. Reinstall the rear panels on the I/O section of the UPS cabinet and the transformer cabinet.
6. Remove the gland plate in the top or bottom of the I/O section of the UPS cabinet.

Top and Bottom Front View of the UPS Cabinet

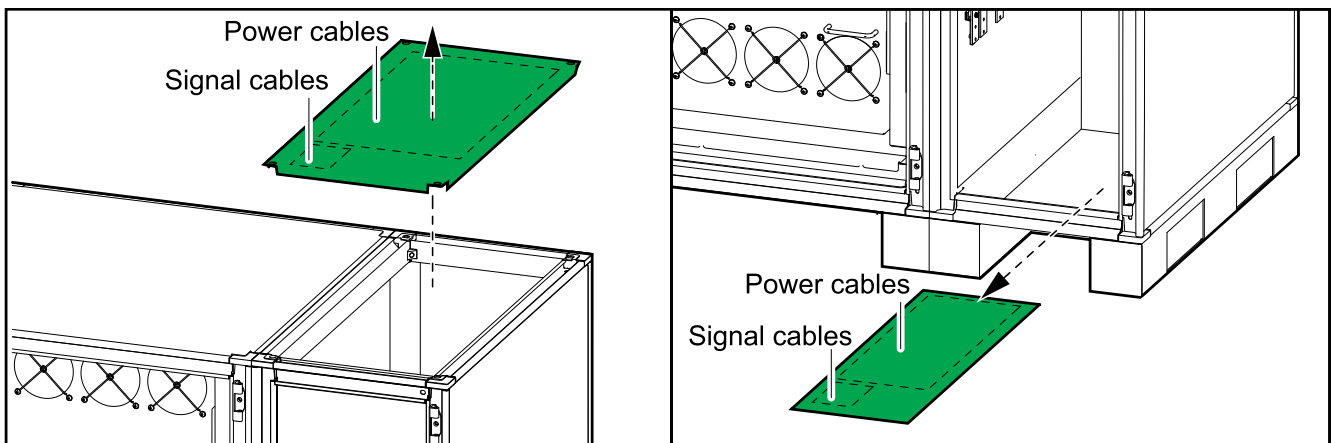

7. Drill holes and install conduits for power cables and for signal cables in the gland plate. Conduits are not provided.

⚠ DANGER

HAZARD OF ELECTRIC SHOCK, EXPLOSION, OR ARC FLASH

Do not drill or cut holes for cables or conduits with the gland plate installed and do not drill or cut holes in close proximity to the UPS.

Failure to follow these instructions will result in death or serious injury.

8. Reinstall the gland plate in the top or bottom of the I/O section of the UPS cabinet.

Prepare the UPS Cabinet for Cables in Systems with Adjacent Battery Cabinet(s)

1. Remove the plate in the bottom left side of the power section of the UPS cabinet.

Front View of the UPS Cabinet

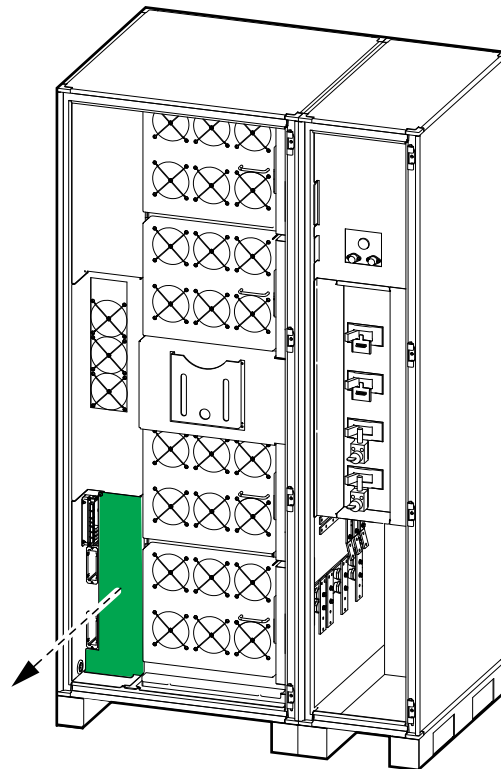

2. Note the position of the two busbars inside the power section of the UPS cabinet and mark it on the left side panel.
3. Note the position of the cable inlet in the power section of the UPS cabinet and mark it on the left side panel.

4. Remove the left side panel from the power section of the UPS cabinet.

Front View of the UPS Cabinet

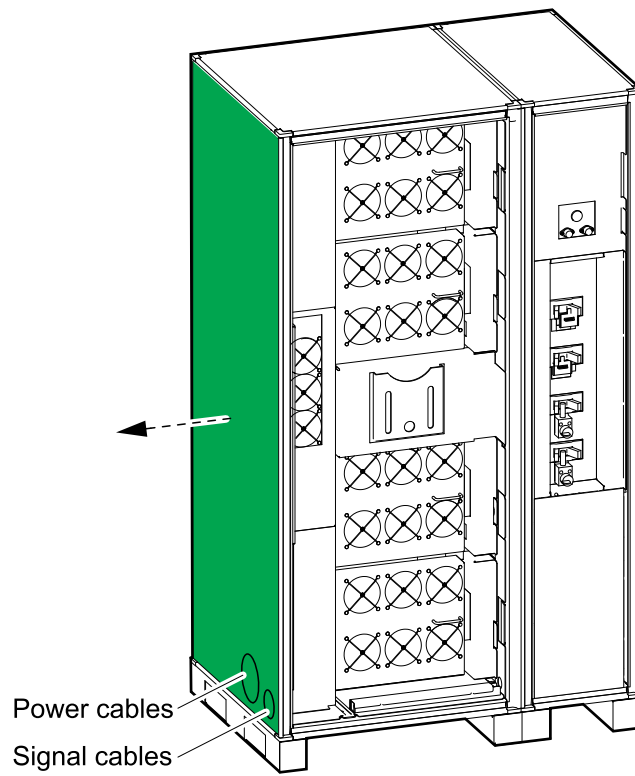

5. Drill holes and install conduits for signal cables and power cables in the side panel. Conduits are not provided.

⚠ DANGER

HAZARD OF ELECTRIC SHOCK, EXPLOSION, OR ARC FLASH

Do not drill or cut holes for cables or conduits with the side panel installed and do not drill or cut holes in close proximity to the UPS.

Failure to follow these instructions will result in death or serious injury.

Front View of the UPS Cabinet

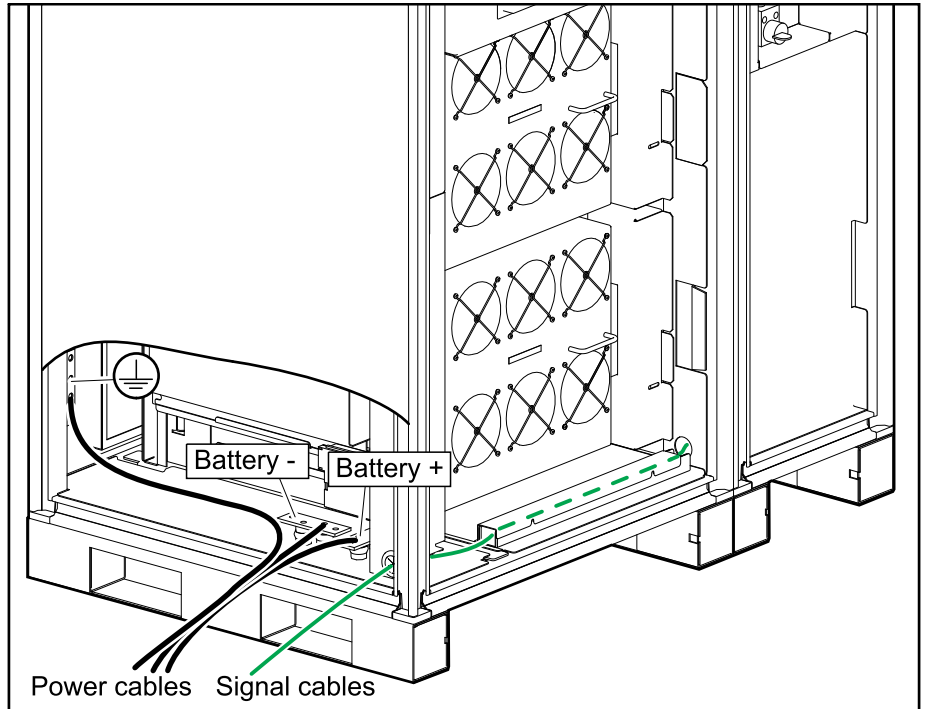

6. Reinstall the side panel in the power section of the UPS cabinet.

Connect the Power Cables for Single Mains

1. Route the input cables through the top or bottom of the I/O section of the UPS cabinet and connect the input cables to the input busbars (L1, L2, L3, N) and to the ground busbar. The neutral cable connects in the left side of the I/O section of the UPS cabinet.

- Route the output cables through the top or bottom of the I/O section of the UPS cabinet and connect the output cables to the output busbars (L1, L2, L3, N) and to the ground busbar. The neutral cable connects in the left side of the I/O section of the UPS cabinet.

Front View of the Busbars in the I/O Section of the UPS Cabinet

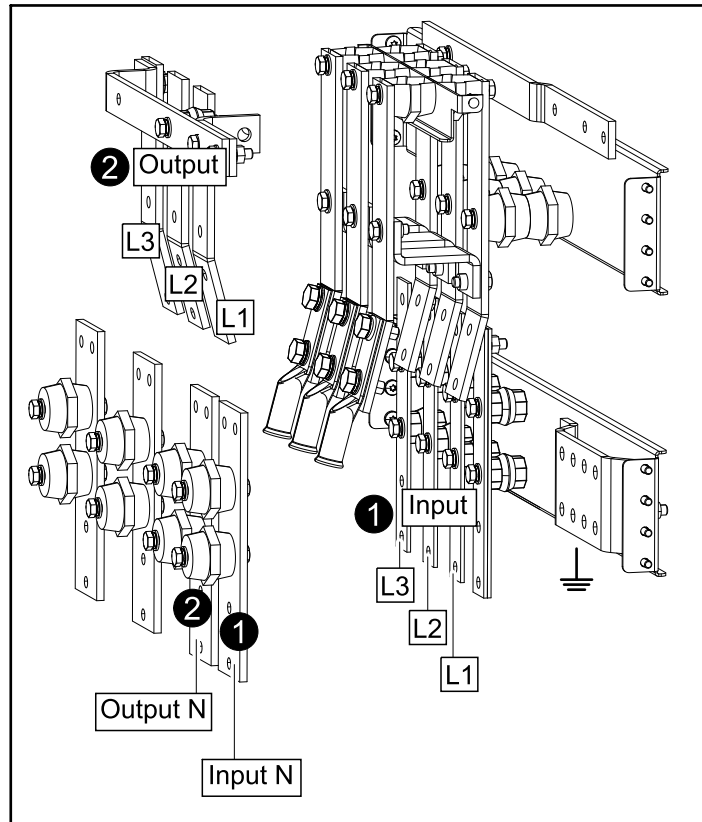

- Route the preinstalled cables labelled **MIB LOAD** through the right side into the transformer cabinet and connect to the busbars (input N to H0, L1 to H1, L2 to H2, L3 to H3) on the input transformer.

4. Route the preinstalled cables labelled **INPUT** through the right side into the transformer cabinet and connect to the busbars (Output N to X0, L1 to X1, L2 to X2, L3 to X3) on the input transformer.

Front View of the Busbars in the I/O Section of the UPS Cabinet and Transformer Cabinet

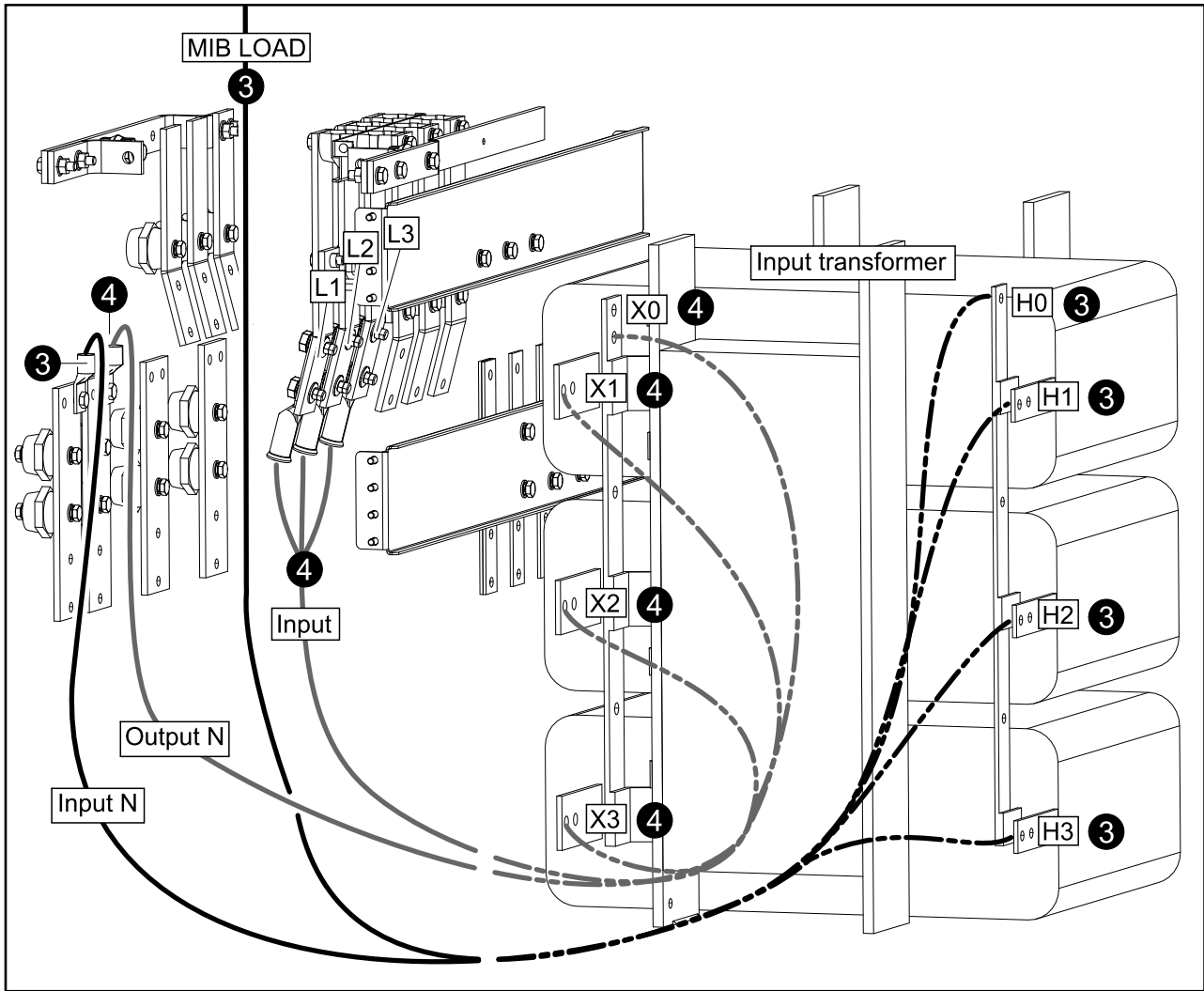

5. **Only in systems with remote battery cabinet(s):** Route the battery cables through the top or bottom of the I/O section of the UPS cabinet and connect the battery cables to the battery busbars (+, –) and to the ground busbar.

NOTE: These battery busbars are only for remote battery cabinets.

Front View of the Busbars in the I/O Section of the UPS Cabinet

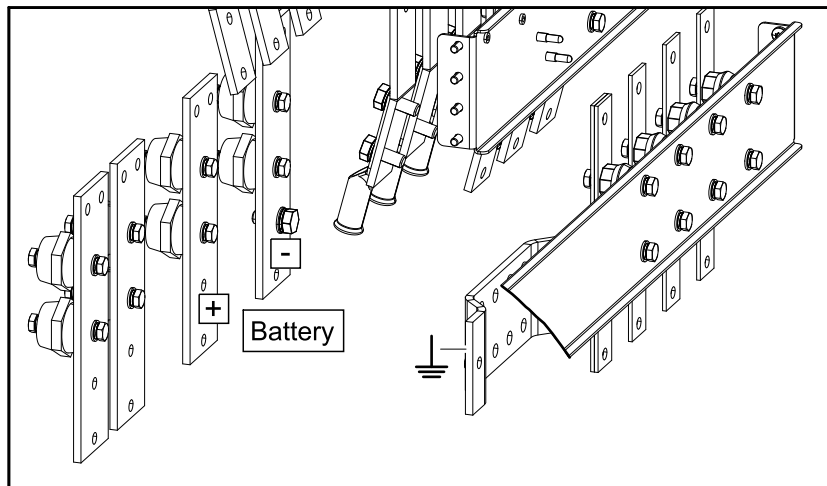

6. **Only in systems with adjacent battery cabinet(s):** Route the battery cables through the left side panel and connect them to the battery busbars (+, –) and the ground busbar in the power section of the UPS cabinet.

NOTE: These battery busbars are only for adjacent battery cabinets.

Front View of the UPS Cabinet

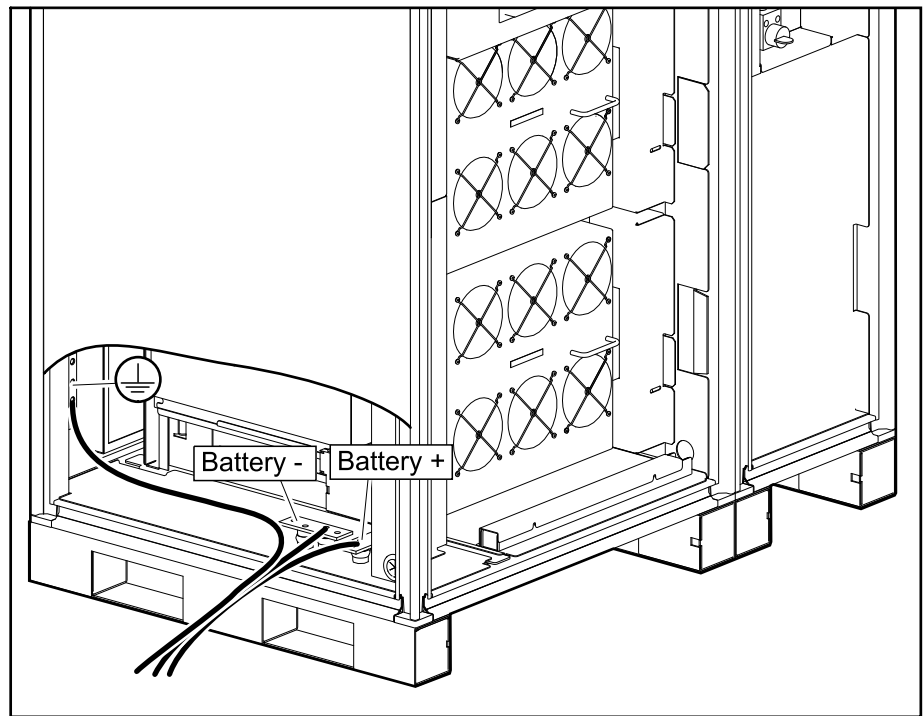

Connect the Power Cables for Dual Mains

1. Route the bypass cables through the top or bottom of the I/O section of the UPS cabinet and connect the bypass cables to the bypass busbars (L1, L2, L3, N) and to the ground busbar.
2.
 - **For 3-wire input system:** Route the input cables through the top or bottom of the I/O section of the UPS cabinet and connect the input cables to the input busbars (L1, L2, L3) and to the ground busbar.
 - **For 4-wire input system:** Route the input cables through the top or bottom of the I/O section of the UPS cabinet and connect the input cables to the input busbars (L1, L2, L3, N) and to the ground busbar.

3. Route the output cables through the top or bottom of the I/O section of the UPS cabinet and connect the output cables to the output busbars (L1, L2, L3, N) and to the ground busbar.

Front View of the Busbars in the I/O Section of the UPS Cabinet

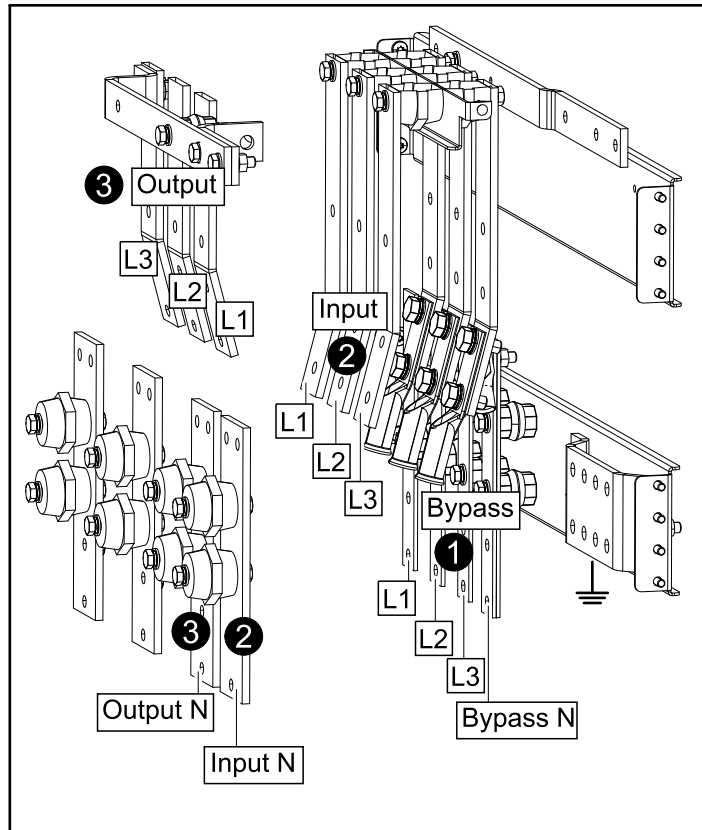

4. Route the preinstalled cables labelled **UIB LOAD** through the right side into the transformer cabinet and connect to the busbars (input N to H0, L1 to H1, L2 to H2, L3 to H3) on the input transformer.

- Route the preinstalled cables labelled **W001** through the right side into the transformer cabinet and connect to the busbars (output N to X0, L1 to X1, L2 to X2, L3 to X3) on the input transformer.

Front View of the Busbars in the I/O Section of the UPS Cabinet and Transformer Cabinet

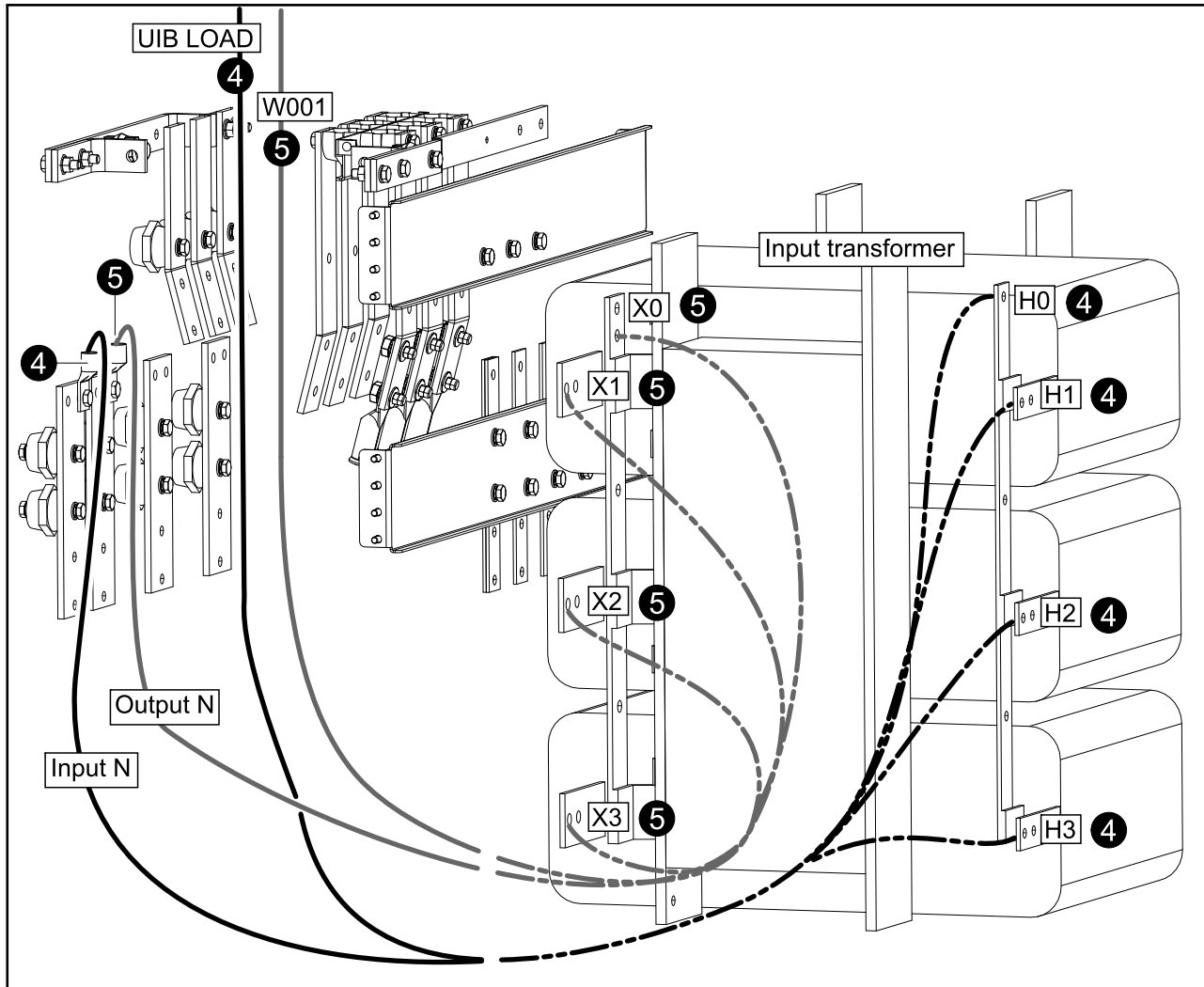

- Route the preinstalled cables labelled **BIB LOAD** through the right side into the transformer cabinet and connect to the busbars (bypass N to H0, L1 to H1, L2 to H2, L3 to H3) on the bypass transformer.

7. Route the preinstalled cables labelled **SSIB LINE** through the right side into the transformer cabinet and connect to the busbars (output N to X0, L1 to X1, L2 to X2, L3 to X3) on the bypass transformer.

Front View of the Busbars in the I/O Section of the UPS Cabinet and Transformer Cabinet

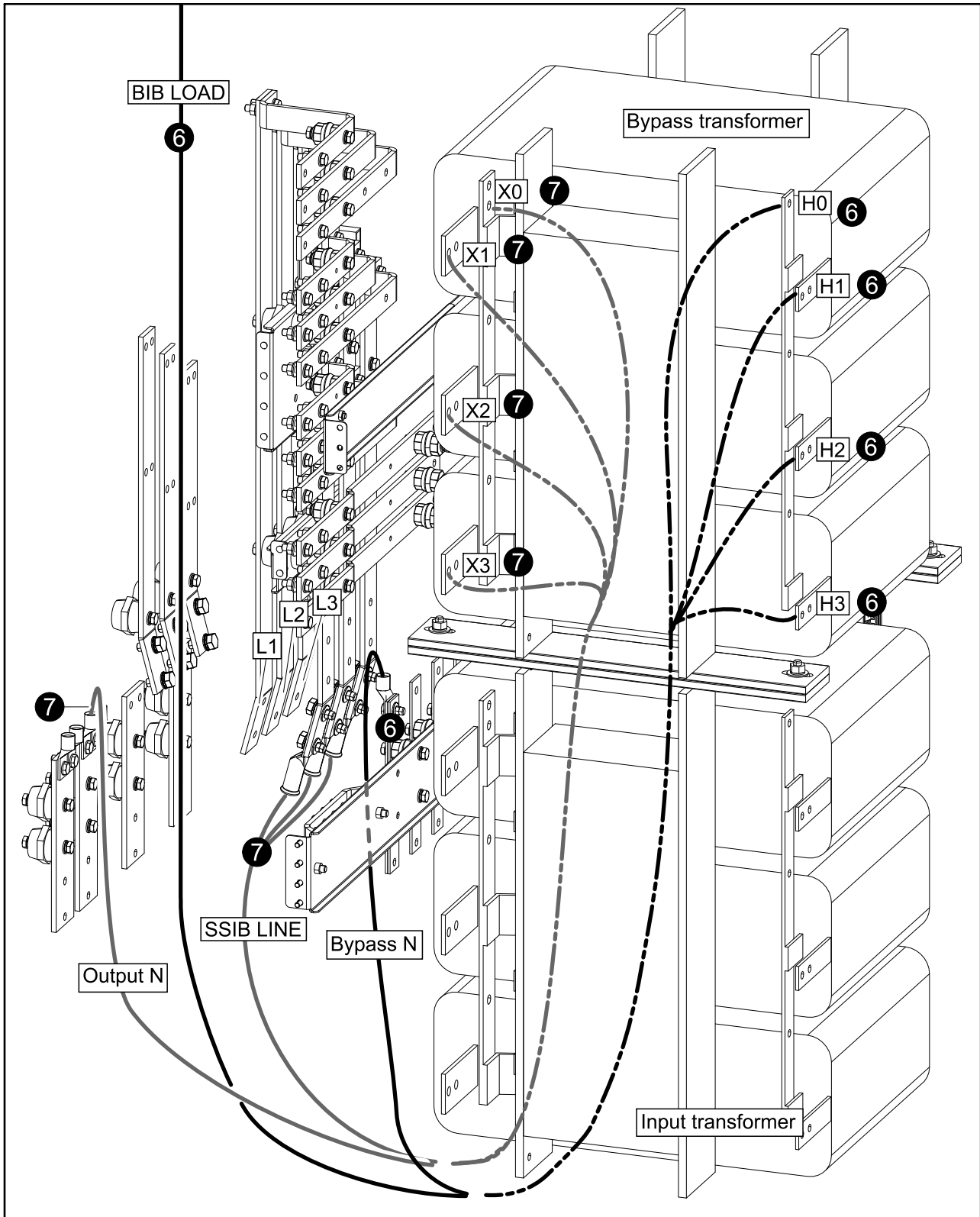

- 8. **Only in systems with remote battery cabinet(s):** Route the battery cables through the top or bottom of the I/O section of the UPS cabinet and connect the battery cables to the battery busbars (+, –) and to the ground busbar.

NOTE: The battery busbars in the I/O section of the UPS cabinet are only for remote battery cabinets.

Front View of the Busbars in the I/O Section of the UPS Cabinet

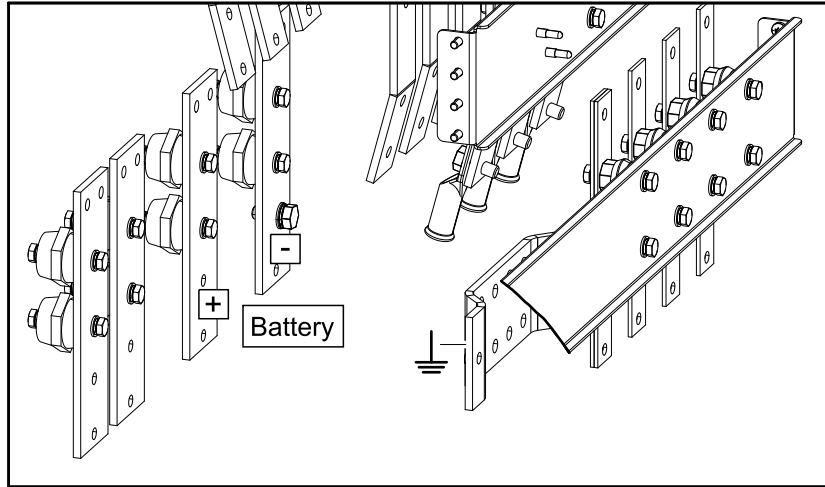

- 9. **Only in systems with adjacent battery cabinet(s):** Route the battery cables through the left side panel and connect them to the battery busbars (+, –) and the ground busbar in the power section of the UPS cabinet.

NOTE: The battery busbars in the power section of the UPS cabinet are only for adjacent battery cabinets.

Front View of the UPS Cabinet

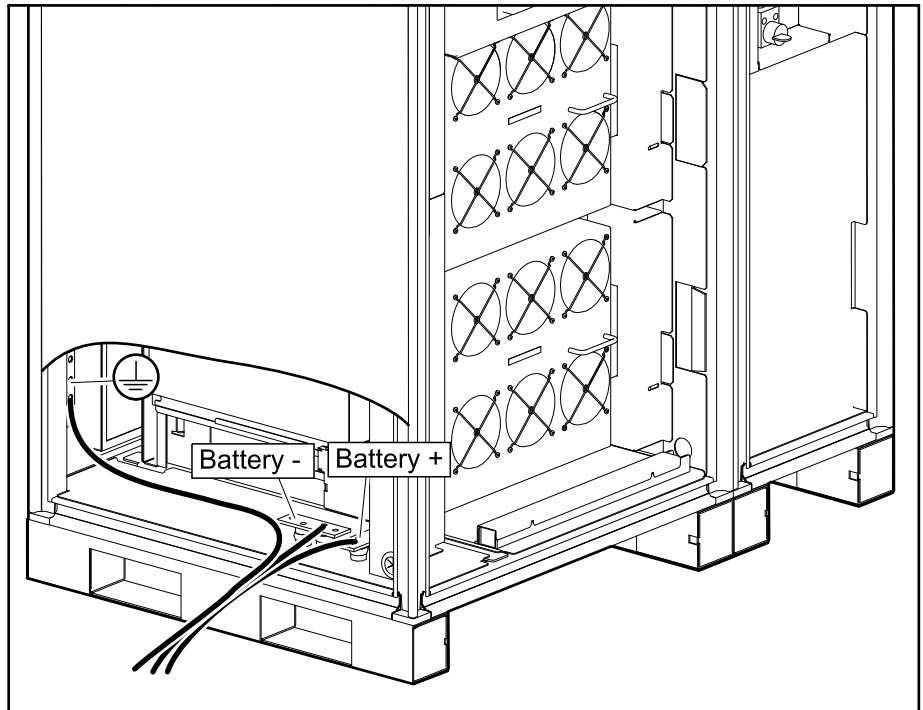

Route the Signal Cables

NOTE: Battery cables and signal cables must be routed separately to reduce noise.

1. Remove the plate in the bottom left side of the power section of the UPS cabinet.
2. Remove the cable channel cover in the power section of the UPS cabinet.

Front View of the Power Section of the UPS Cabinet

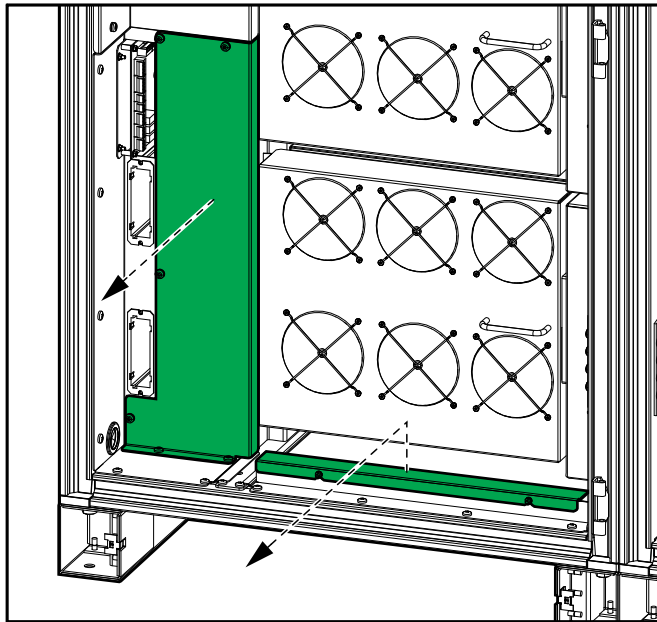

3. Route the signal cables through the top or bottom of the I/O section of the UPS cabinet to the control terminal block TB1.

Front View of the I/O Section of the UPS Cabinet

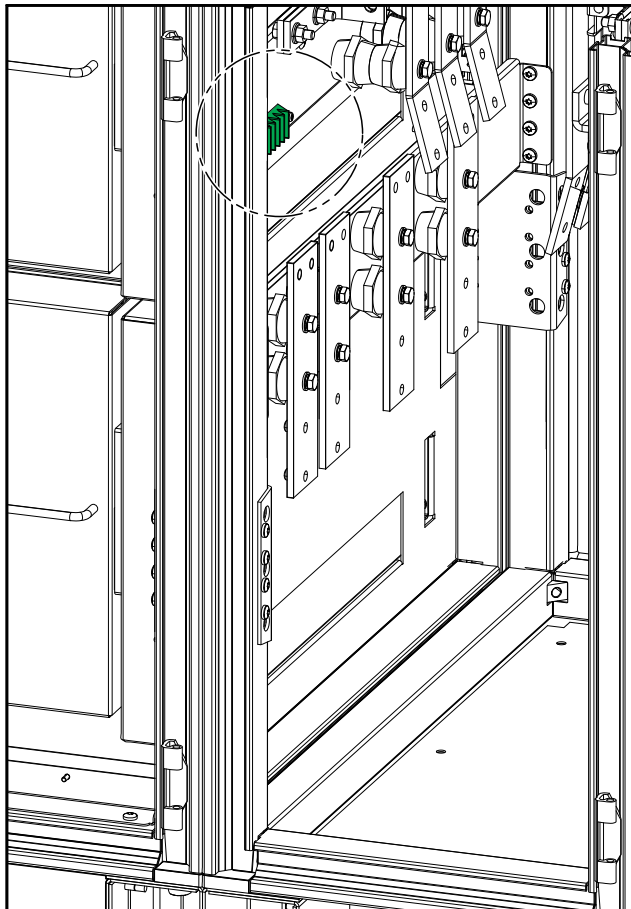

4. **Only in systems with adjacent battery cabinet(s):** Route the signal cables from the adjacent battery cabinet(s) through the cable channel in the power section of the UPS cabinet to the control terminal block TB1 in the I/O section of the UPS cabinet as shown.

Front View of the UPS Cabinet

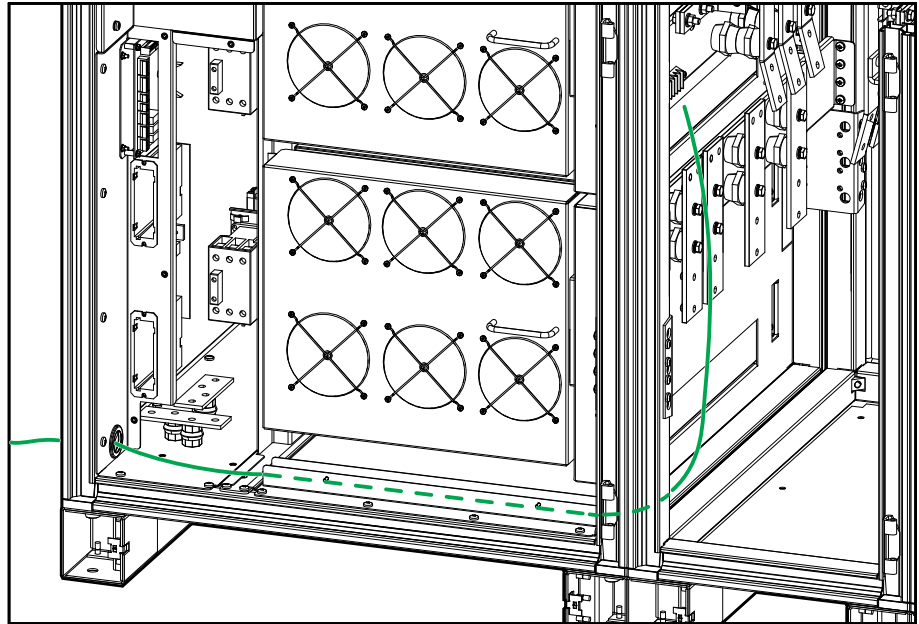

5. Route the signal cables through the top or bottom of the I/O section of the UPS cabinet through the cable channel in the power section of the UPS cabinet to the external connection board 0P2553.

Front View of the UPS Cabinet

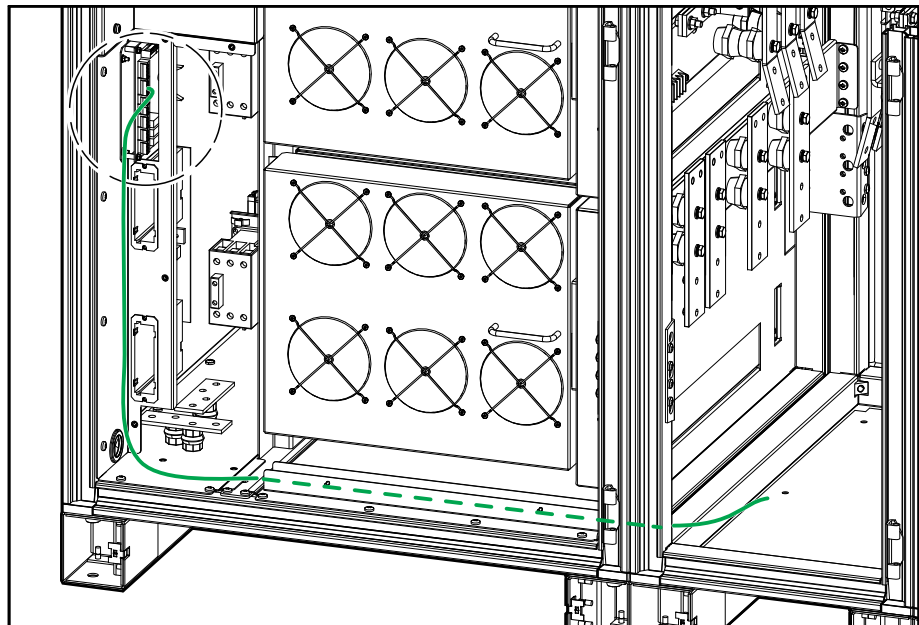

Connect the Signal Cables

Overview of the External Connection Board 0P2553

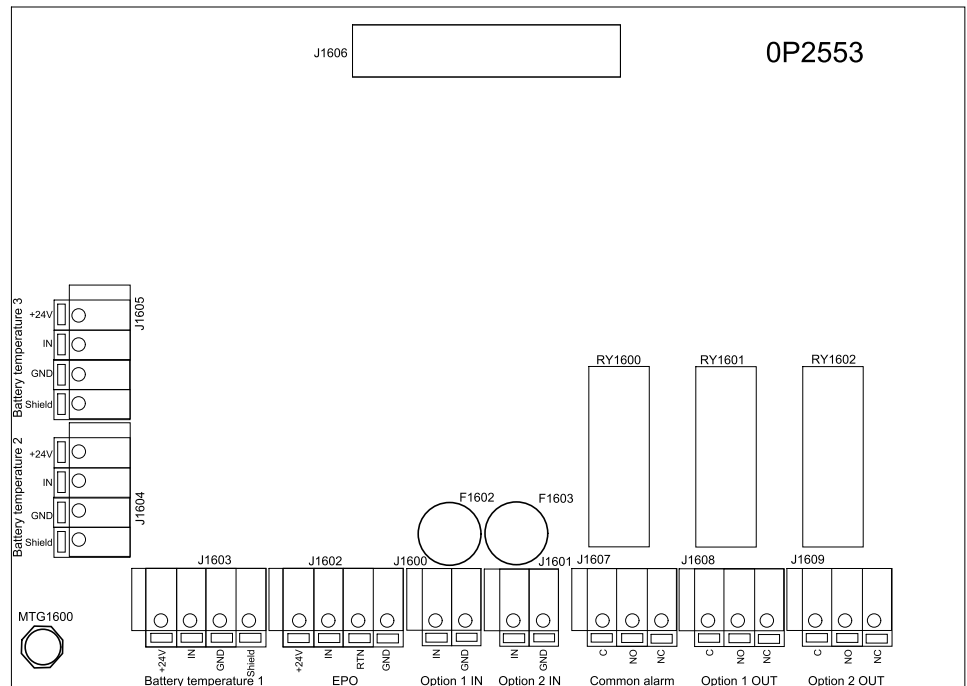

Connections are described in *Connect the Battery Signal Cables*, page 35, *Connect the Remote Emergency Power Off (REPO)*, page 38, and *Connect the Input Contacts and Output Relays (Option)*, page 39.

Connect the Battery Signal Cables

NOTE: Maximum distance between the UPS cabinet and the remote battery cabinet(s) is 30 meters.

1. Connect the signal cables from the control terminal block TB1 in the battery cabinet(s) or the battery breaker box to the control terminal block TB1 in the UPS cabinet as shown.

Signal Cable Connections with One Battery Cabinet

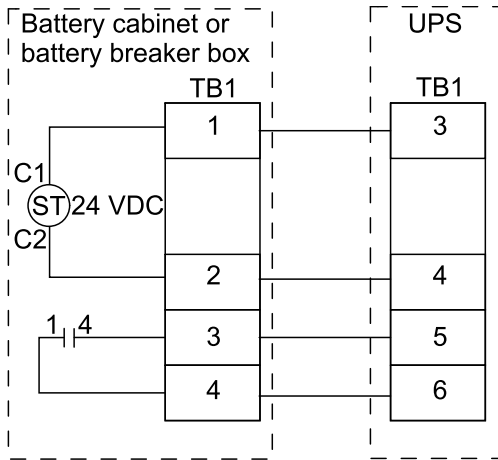

Signal Cable Connections with Three Battery Cabinets

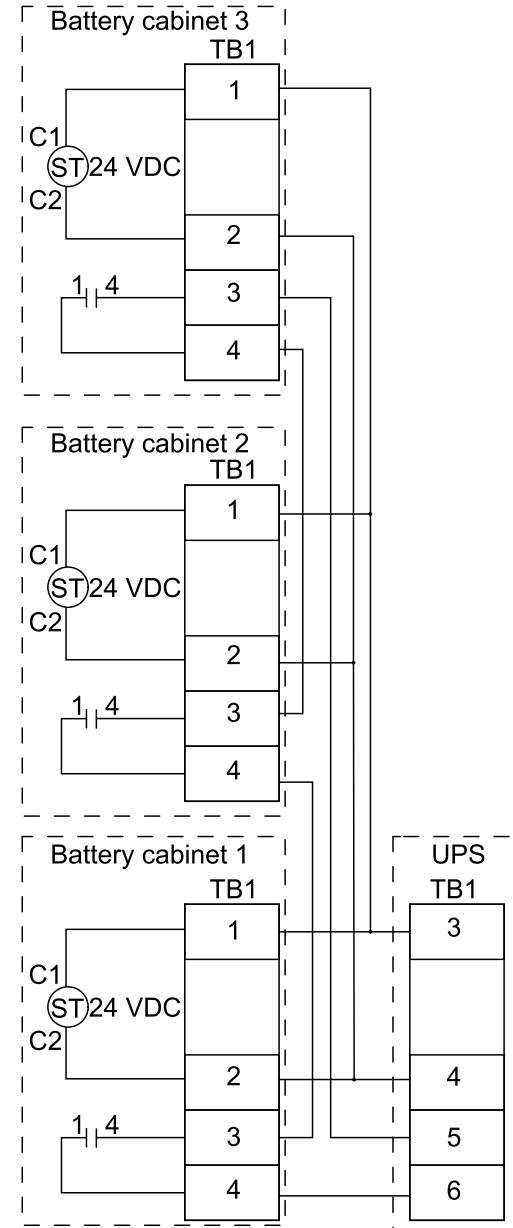

Signal Cable Connections with Two Battery Cabinets

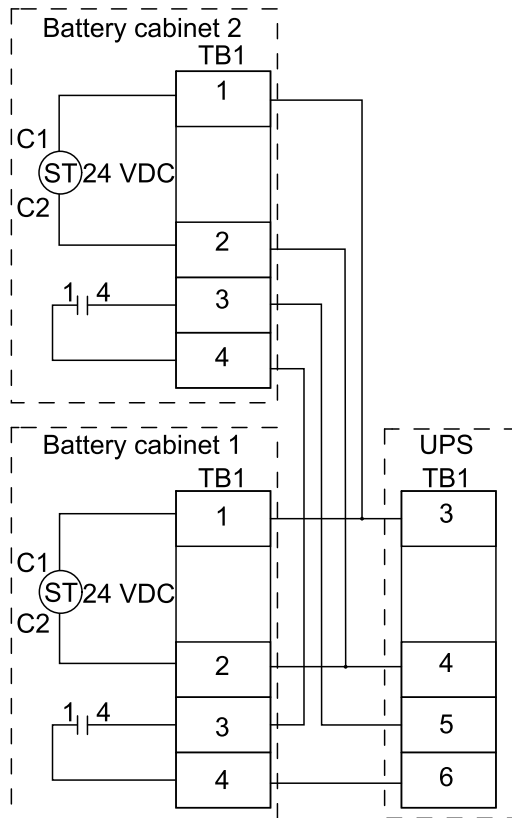

2. **Only in systems with adjacent battery cabinet(s):** Connect the signal cables from the battery temperature sensor in the battery cabinet(s) to the external connection board 0P2553 in the UPS cabinet as shown.

Cable Connections for Temperature Sensors in Adjacent Battery Cabinets

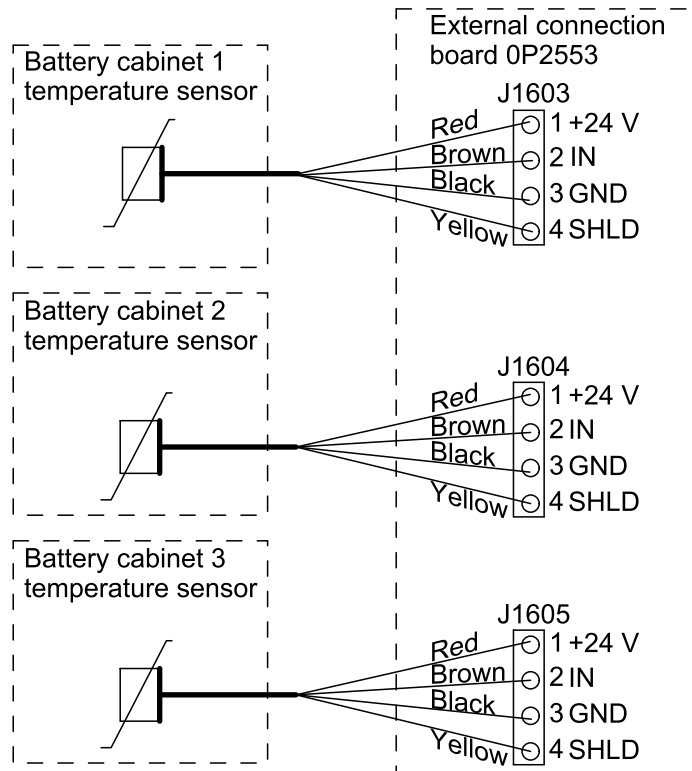

3. **Only in systems with remote battery cabinet(s):** Connect the signal cables from the battery temperature sensor to pins 5-8 on the control terminal block TB1 in the battery cabinet(s) as shown.

4. **Only in systems with remote battery cabinet(s):** Connect the signal cables from pins 5-8 on the control terminal block TB1 in the battery cabinet(s) to the external connection board 0P2553 in the UPS cabinet as shown. Note that you will need a cable (not provided) with three wires and a shield with a maximum length of 30 meters for this step. Recommended cable size is 22 AWG.

Cable Connections for Temperature Sensors in Remote Battery Cabinets

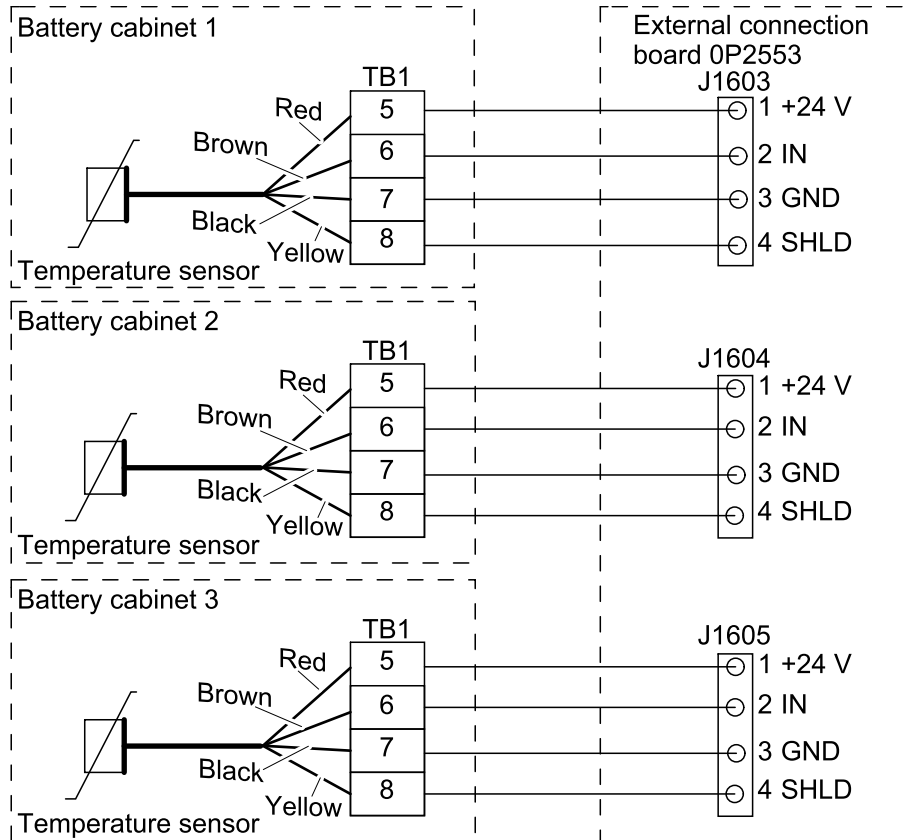

Connect the Remote Emergency Power Off (REPO)

The REPO circuit is considered Class 2 and SELV. Class 2 and SELV circuits must be isolated from the primary circuitry. Do not connect any circuit to the REPO terminal block unless it can be confirmed that the circuit is SELV or Class 2.

NOTE: This UPS uses two isolated REPO circuits. Both REPO circuits must be connected for full EPO of the system. Use a double pole single throw switch.

NOTE: Do not tie the connections from TB1 and the external connection board 0P2553 together.

1. Remove the jumper between terminals 1 and 2 on J1602 on the external connection board 0P2553 in the UPS.
2. Remove the jumper between pins 1 and 2 on the control terminal block TB1 in the UPS.
3. Connect the building REPO as a REPO with internal supply or as a REPO with external supply as shown. The control terminal block TB1 must always be connected to the internal supply (dry contact), the external connection board 0P2553 can be connected to the internal supply or to an external 24 VDC supply.

4. Fasten the REPO cables.

REPO with Internal Supply

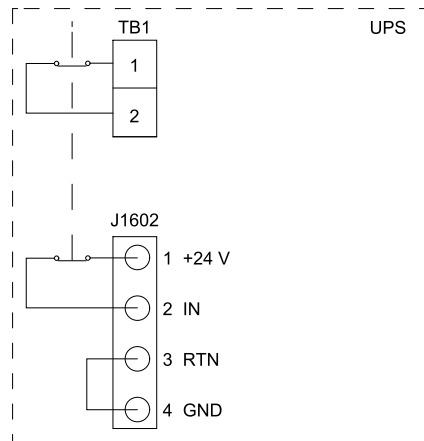

REPO with 24 VDC External Supply, Maximum 20 mADC

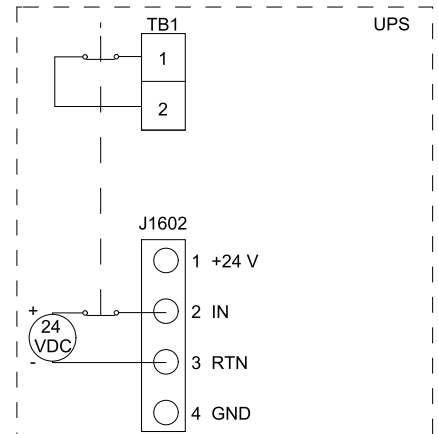

Connect the Input Contacts and Output Relays (Option)

1. Connect the signal cables to the input contacts and output relays on the external connection board 0P2553.

Input Contacts and Output Relays Configuration Settings

The default configuration settings are shown.

Name	Description	Location on external connection board 0P2553	Value
Option 1 IN	Input contact: Block boost/initial charge	J1600	Closed state: Disable boost charge
Option 2 IN	Input contact: Force to boost charge	J1601	Closed state: Start boost charge
Common alarm	Output relay: Common alarm	J1607	Normally open (NO)/ Normally closed (NC) Maximum 250 VAC, 8 A Maximum 24 VDC, 8 A
Option 1 OUT	Output relay: Battery operation	J1608	
Option 2 OUT	Output relay: Static bypass operation	J1609	

Final Installation Steps

1. Reinstall all covers and plates on the cabinet(s).
2. **Only for seismic anchoring:** Install the front seismic anchoring bracket on the cabinet(s).

Front View

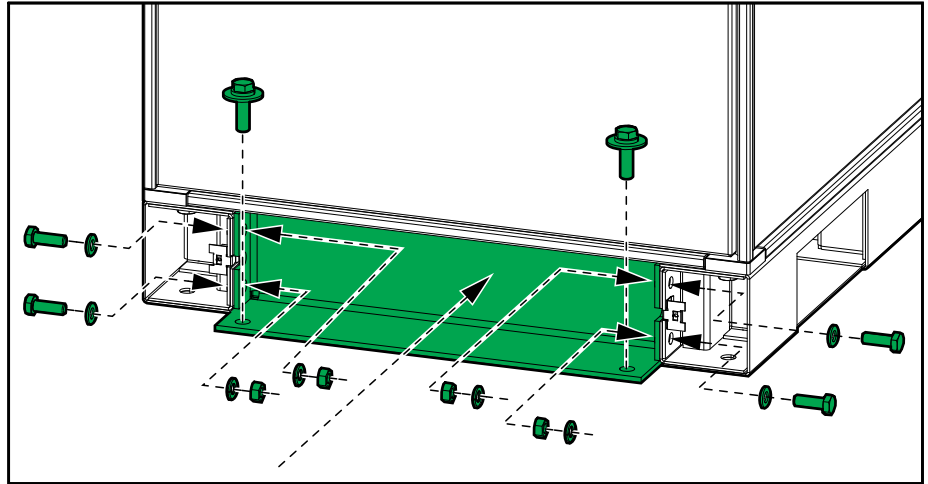

3. Reattach the kick plates to the spring clips on the cabinet(s).

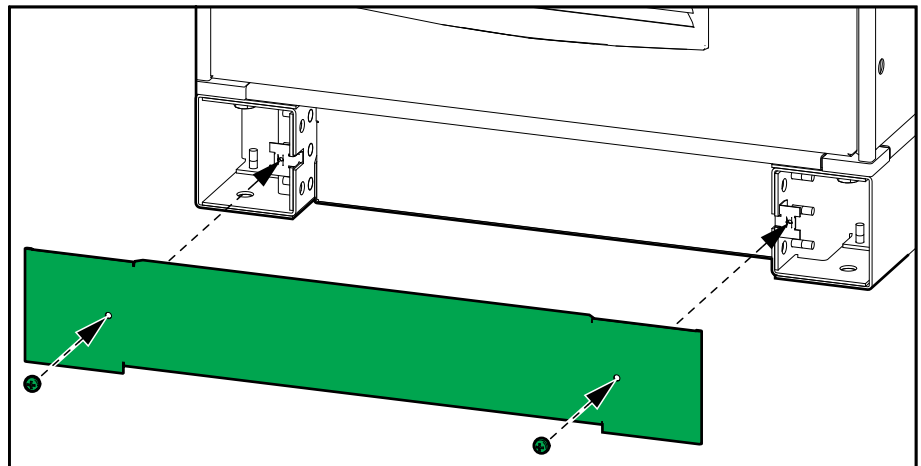

4. Fasten the kick plates with the M5 screws.

Schneider Electric
35 rue Joseph Monier
92500 Rueil Malmaison
France

+ 33 (0) 1 41 29 70 00

www.schneider-electric.com

As standards, specifications, and design change from time to time,
please ask for confirmation of the information given in this publication.

© 2017 – 2017 Schneider Electric. All rights reserved.

990-5921-001